

MIXER WITH CONVENTIONAL CONNECTION (DRIVE HOOK)

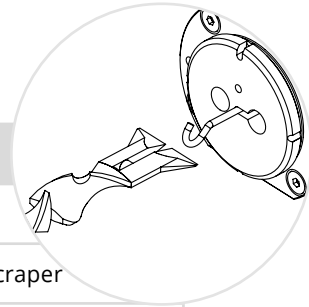

QTY	UNIT	ART. NO.	DESCRIPTION
	100 Pcs.	06/12 D	Disposable mixer 6 mm x 12 mixing elements, dynamic
	100 Pcs.	06/12 DA	Disposable mixer 6 mm x 12 mixing elements, dynamic, with scraper
	100 Pcs.	06/12 DK	Disposable mixer 6 mm x 12 mixing elements, dynamic, with conus
	100 Pcs.	06/12 DI	Disposable mixer 6 mm x 12 mixing elements, dynamic, with pin for speed control
	100 Pcs.	08/12 D	Disposable mixer 8 mm x 12 mixing elements, dynamic
	100 Pcs.	08/12 DA	Disposable mixer 8 mm x 12 mixing elements, dynamic, with scraper
	100 Pcs.	08/12 DI	Disposable mixer 8 mm x 12 mixing elements, dynamic, with pin for speed control
	100 Pcs.	10/12 D	Disposable mixer 10 mm x 12 mixing elements, dynamic
	100 Pcs.	10/12 DI	Disposable mixer 10 mm x 12 mixing elements, dynamic, with pin for speed control
	50 Pcs.	13/08 CH D	Disposable mixer 13 mm x 8 mixing elements, dynamic, heat resistant up to 200°C
	1 Pcs.	13/08 Stahl	Steel mixer for multiple use, 13 mm x 8 mixing elements
	50 Pcs.	13/12 D	Disposable mixer 13 mm x 12 mixing elements, dynamic
	50 Pcs.	13/12 D LC6	Disposable mixer 13 mm x 12 mixing elements, dynamic, for LC 6/7 mixing head
	50 Pcs.	13/12 DIMHT	Disposable mixer 13 mm x 12 mixing elements, dynamic, with pin for speed control (material output), spout
	50 Pcs.	13/12 DIM	Disposable mixer 13 mm x 12 mixing elements, dynamic, with pin for speed control (material input)
	50 Pcs.	13/12 DIMH	Disposable mixer 13 mm x 12 mixing elements, dynamic, with pin for speed control (material output)
	50 Pcs.	13/12 DIMH LC6	Disposable mixer 13 mm x 12 mixing elements, dynamic, with pin for speed control (material output) for mixing head LC 6/7
	50 Pcs.	13/12 DIMS	Disposable mixer 13 mm x 12 mixing elements, dynamic, with pin for speed control (material input), mounting for centrifugal disc
	50 Pcs.	13/12 DIMT	Disposable mixer 13 mm x 12 mixing elements, dynamic, with pin for speed control (material input), spout
	50 Pcs.	13/12 DT	Disposable mixer 13 mm x 12 mixing elements, dynamic, spout

QTY	UNIT	ART. NO.	DESCRIPTION
	50 Pcs.	13/12 HD	Disposable mixer 13 mm x 12 mixing elements, dynamic, heat resistant up to 200°C
	50 Pcs.	13/24 D	Disposable mixer 13 mm x 24 mixing elements, dynamic
	50 Pcs.	13/24 DIMH	Disposable mixer 13 mm x 24 mixing elements, dynamic, with pin for speed control (material output)
	1 Pcs.	20/06 D	Steel mixer for multiple use, 20 mm x 6 mixing elements
	10 Pcs.	22/04 DS	Disposable mixer 22 mm x 4 mixing elements, dynamic, hose connection to mixer sleeve
	10 Pcs.	22/04 DIS	Disposable mixer 22 mm x 4 mixing elements, dynamic, with pin for speed control, hose connection to mixer sleeve
	10 Pcs.	22/06 DS	Disposable mixer 22 mm x 6 mixing elements, dynamic, hose connection to mixer sleeve
	10 Pcs.	22/06 DIS	Disposable mixer 22 mm x 6 mixing elements, dynamic, with pin for speed control, hose connection to mixer sleeve
	10 Pcs.	22/04 DS 25	Disposable mixer 22 mm x 4 mixing elements, dynamic, hose connection to mixer sleeve (DN 25)
	10 Pcs.	22/06 DS 25	Disposable mixer 22 mm x 6 mixing elements, dynamic, hose connection to mixer sleeve (DN 25)
	10 Pcs.	22/04 DIS 25	Disposable mixer 22 x 4 mixing elements, dynamic, with pin for speed control, hose connection to mixer sleeve (DN 25)
	10 Pcs.	22/06 DIS 25	Disposable mixer 22 x 6 mixing elements, dynamic, with pin for speed control, hose connection to mixer sleeve (DN 25)
	10 Pcs.	35/04 DIS	Disposable mixer 35mm x 4 mixing elements, dynamic, with pin for speed control, hose connection to mixer sleeve
	10 Pcs.	35/08 DIS	Disposable mixer 35 mm x 8 mixing elements, dynamic, with pin for speed control, hose connection to mixer sleeve
	10 Pcs.	35/08 DIS T8	Disposable mixer 35 mm x 8 mixing elements, dynamic, with pin for speed control, aluminum reducing insert on mixer sleeve for higher dynamic pressure

MIXER WITH SELFCUTTING CONNECTION

QTY	UNIT	ART. NO.	DESCRIPTION
	100 Pcs.	06/12 C-D	Selfcutting disposable mixer 6 mm x 12 mixing elements, dynamic
	100 Pcs.	06/12 C-DI	Selfcutting disposable mixer 6 mm x 12 mixing elements, dynamic, with pin for speed control
	100 Pcs.	08/12 C-D	Selfcutting disposable mixer 8 mm x 12 mixing elements, dynamic

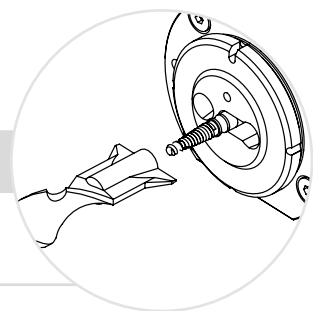

QTY	UNIT	ART. NO.	DESCRIPTION
	100 Pcs.	08/12 C-DI	Selfcutting disposable mixer 8 mm x 12 mixing elements, dynamic, with pin for speed control
	100 Pcs.	10/12 C-D	Selfcutting disposable mixer 10 mm x 12 mixing elements, dynamic
	100 Pcs.	10/12 C-DI	Selfcutting disposable mixer 10 mm x 12 mixing elements, dynamic, with pin for speed control
	50 Pcs.	13/12 C-D	Selfcutting disposable mixer 13 mm x 12 mixing elements, dynamic
	50 Pcs.	13/12 C-DI	Selfcutting disposable mixer 13 mm x 12 mixing elements, dynamic, with pin for speed control
	10 Pcs.	22/04 C-DS	Selfcutting disposable mixer 22 mm x 4 mixing elements, dynamic, hose connection to mixer sleeve
	10 Pcs.	22/04 C-DIS	Selfcutting disposable mixer 22 mm x 4 mixing elements, dynamic, with pin for speed control, hose connection to mixer sleeve
	10 Pcs.	22/04 C-DIS 12	Selfcutting disposable mixer 22 mm x 4 mixing elements, dynamic, with pin for speed control, hose connection (DN 12) to mixer sleeve
	10 Pcs.	22/04 C-DIS 25	Selfcutting disposable mixer 22 mm x 4 mixing elements, dynamic, with pin for speed control, hose connection (DN 25) to mixer sleeve
	10 Pcs.	22/06 C-DIS	Selfcutting disposable mixer 22 mm x 6 mixing elements, dynamic, with pin for speed control, hose connection to mixer sleeve
	10 Pcs.	22/06 C-DS	Selfcutting disposable mixer 22 mm x 6 mixing elements, dynamic, hose connection to mixer sleeve
	10 Pcs.	35/08 C-DIS	Selfcutting disposable mixer 35 mm x 8 mixing elements, dynamic, with pin for speed control, hose connection to mixer sleeve

STATIC MIXER

QTY	UNIT	ART. NO.	DESCRIPTION
	100 Pcs.	06/24	Disposable mixer 6 mm x 24 mixing elements, static
	100 Pcs.	08/24	Disposable mixer 8 mm x 24 mixing elements, static
	100 Pcs.	08/32	Disposable mixer 8 mm x 32 mixing elements, static
	100 Pcs.	10/24	Disposable mixer 10 mm x 24 mixing elements, static
	100 Pcs.	10/32	Disposable mixer 10 mm x 32 mixing elements, static
	50 Pcs.	13/24	Disposable mixer 13 mm x 24 mixing elements, static
	50 Pcs.	13/32	Disposable mixer 13 mm x 32 mixing elements, static
	10 Pcs.	20/18	Disposable mixer 20 mm x 18 mixing elements, static
	10 Pcs.	20/23	Disposable mixer 20 mm x 23 mixing elements, static
	10 Pcs.	20/32	Disposable mixer 20 mm x 32 mixing elements, static

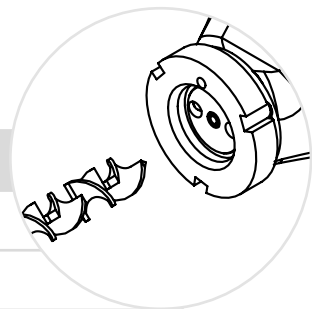

MIXER SLEEVES

QTY	UNIT	ART. NO.	DESCRIPTION
	100 Pcs.	06/04 DH	Disposable mixing sleeve for mixer 06/12
	50 Pcs.	13/12 DH	Disposable mixing sleeve for mixer 13/12
	50 Pcs.	13/12 DH LC6	Disposable mixing sleeve for mixer 13/12 D LC6
	10 Pcs.	22/04 DHS	Disposable mixing sleeve with hose connection for mixer 22/04
	10 Pcs.	22/04 DHS 25	Disposable mixing sleeve with hose connection (DN 25) for mixer 22/04

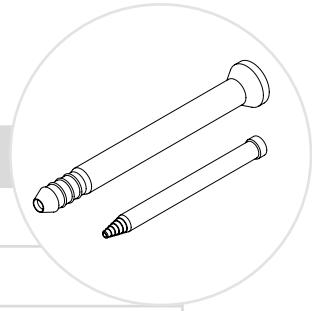

OTHER CONSUMABLE PARTS

QTY	UNIT	ART. NO.	DESCRIPTION
	10 Pcs.	EK20-1157	Hose clamp (DN 9) for 13/12 DT mixer
	10 Pcs.	EK20-1158	Hose clamp (DN 13) for 13/12 DT mixer
	10 Pcs.	EK20-0780	Hose clamp (DN 19) for 22 mm mixer
	10 Pcs.	EK20-0781	Hose clamp (DN 24) for 22 mm und 35 mm mixer
	10 Pcs.	EK20-1154	Hose clamp (DN 32) for 35 mm mixer
	10 Pcs.	EK20-0016	Nozzle for paste, 70 x 31 mm
	10 Pcs.	EK20-0017	Nozzle for paste, rotatable, 78 x 41 mm
	10 Pcs.	EK20-1093	Nozzle for paste, rotatable, 70 x 31 mm
	50 Pcs.	EK30-0178	Nozzle holder for mixer 06 mm und 08 mm
	50 Pcs.	EK30-0179	Nozzle holder for mixer 10 mm und 13 mm
	50 Pcs.	EK20-0073	Flat nozzle, 40 mm
	50 Pcs.	EK20-0074	Flat nozzle, 60 mm
	50 Pcs.	EK20-0075	Flat nozzle, 80 mm
	50 Pcs.	EK20-0072	Flat nozzle variable, max. 120 mm
	50 Pcs.	EK20-0274	Flowstop (black), self sealing mould connection for 13 mm mixer, suitable for approx. 10 up to 30 bar cavity pressure, shore hardness A80
	50 Pcs.	EK20-2575	Flowstop (blue), self sealing mould connection for 13 mm mixer, suitable for approx. 0 up to 30 bar cavity pressure, shore hardness A80
	50 Pcs.	EK20-2615	Flowstop (green), self sealing mould connection for 13 mm mixer, suitable for approx. 0 up to 10 bar cavity pressure, shore hardness A55
	10 Pcs.	EK20-0788	Centrifugal discs for rotational output of material, Ø 50 mm
	10 Pcs.	EK20-0789	Centrifugal discs for rotational output of material, Ø 80 mm

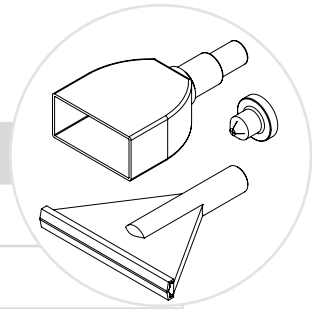

QTY	UNIT	ART. NO.	DESCRIPTION
	10 Pcs.	EK20-2193	Y-connector/distributor 19/19/25 mm
	10 Pcs.	EK20-1919	Y-connector/distributor 19/19/19 mm
	10 Pcs.	EK20-2641	Y-connector/distributor 25/25/25 mm

CONTACT

Mrs. Mr.

First name	Surname
Company	VAT
Street, No.	ZIP, city
Country	
Phone	Email
Message	

By submitting this form, I confirm that I have read and understood the [privacy policy](#). I agree that my information and data will be collected and stored electronically to answer my request. I can revoke the consent at any time for the future by mail.

Please send your request to

verkauf@tartler.com



For more information on accessories and consumables, please visit our website:

► <https://www.tartler.com/en/products/accessories-consumables>



TARTLER GmbH
 Relystr. 48
 D-64720 Michelstadt
 Phone: +49 6061 9672-0
www.tartler.com

EXPLANATION OF THE MIXER TERMS

13/12 (example for mixer key)	13 mm inner diameter in pipe / 12 = number of mixer elements
D	Dynamic
I	Initiator (speed monitoring), shortcut: Ini
A	Scraper at mixer inlet / mixer head outlet for materials that tend to form agglomerates
K	Cone (for possible closure of the mixer outlet after the end of the shot (expanding systems) or for thixotropic adhesives / synthetic resins that would clog the mixer outlet)
C	Self-cutting mixer connection
DH	Sleeves (mixer sleeves)
T	Nozzle (hose nozzle connection)
IM	Initiator at mixer input (speed monitoring)
IMH	Initiator at mixer output (speed monitoring)
S	Hose connection to mixer sleeve

NEW

INTRODUCTION: SELF-CUTTING MIXER CONNECTION

The self-cutting mixer connection developed and patented by us is intended to replace the conventional connection with drive hook in the long term. A mixture of screw and corkscrew turns into the mixer and can be released again with the opposite direction of rotation. This increases work safety for the operator and completely eliminates the potential risk of injury from the drive hook. As the mixer does not have to be hooked into a hook, it is also possible to automate the mixer change. Cleaning and changing a cured mixer are also easier than with the previous model.

In summary

- ▶ Automated mixer change possible
- ▶ Easy cleaning
- ▶ Trouble-free mixer change even with hardened mixer
- ▶ Higher working safety due to improved shaft geometry
- ▶ Low maintenance, as sealing only against A-component
- ▶ More stable, low-maintenance design
- ▶ Simple and safe maintenance assembly